

# PARKFIELD Pressure Balance Valve Shower Combination

MODEL # 35040

*Pure Freude an Wasser*

**GROHE**

GROHE America, Inc | 200 North Gary Avenue, Suite G, Roselle, IL 60172  
Phone: +1 (800) 444-7643 | Fax: +1 (800) 225-2778 | us-customerservice@grohe.com

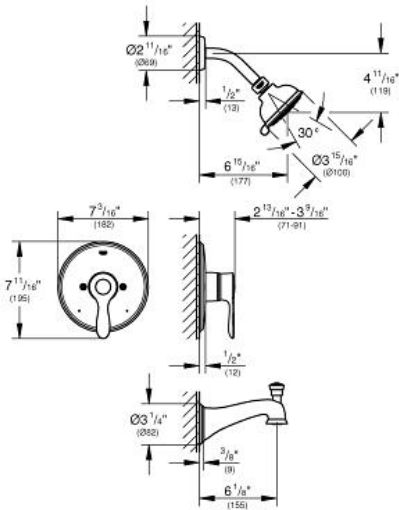

## Product Description:

### Pressure Balance Valve Shower Combination

#### Standard Specification:

- Pressure Balance Valve Trim (19 921)
- 5 5/8" Tubular shower arm (27 414)
- Diverter Tub Spout (13 338)
- **GROHE StarLight®** finish

#### Applicable Codes & Standards:

- Energy Policy Act of 1992
- ASME A112.18.1/CSA B125.1

#### Color:

- 35040 000 chrome
- 35040 EN0 brushed nickel